

# TECHNICAL ENGINEERING EVALUATIONS AND ECONOMIC FEASIBILITY STUDY OF SOLAR POWERED AIR CONDITIONING SYSTEM IN TIER THREE NATIONS

**AbdulKhab Dywju, Waidsum University**  
**Fheroz Shan, Onaizah College**  
**Mohamod Habi Habi, International Islamic University**  
**Sherifah Oshioke Musa, Waidsum University**

## ABSTRACT

*This article focuses on the analysis and integration of PV systems to load ratio correlation and the economic importance of the left over to grid supply and integration. The paper focusses on the different methods of PV generation to load utilization using the solar powered air conditioner as the load while minimizing the use of fossil fuel (petroleum, natural gas and coal) which have serious environmental implications. Air conditioners are becoming more commonly used load power consumption metrics and are a major strain on energy demands especially in tropical rainforest climate countries like Nigeria. The photovoltaic electricity is a clean and sustainable energy. In this paper, we present a techno-economic feasibility study for solar powered air conditioning system in Nigeria. The method used made a correlation of four alternatives of PV to load ratio factor being investigated. In the first instance, the PV system supplied 50% of the energy to the loads. In the second method, the PV system supplied 75% of the energy to the loads. Thirdly, the PV system supplied 100% of the energy to the loads. Fourthly, on a final design, the PV system supplied 125% of the energy to the loads. In the first two case the PV energy generated is used solely to power the air conditioner system. In the last two design, there is excess electrical energy which is proposed to be sold to the Nigeria grid system especially if the grid system optimized and broken down into smaller grid array within 0.3\$ feed-in tariff. The best alternative method is the grid-connected PV system with 125% capacity factor which is chosen due to its short payback time period as well as high profit rate over the lifetime of the project.*

**Keywords:** PV System, Mini Grid Array, Electrical loads, Payback Time Period, Air Conditioning System, Load utilization, Solar Energy Generation, Load Power Consumption Metrics, Techno-Economic Feasibility, Solar Powered Air Conditioner, PV to Load Ratio

## INTRODUCTION

Nowadays, green energy has proven significant in solving electricity problems. However, a great amount of fossil fuel (petroleum, natural gas and coal) is being burnt which results in a significant amount of greenhouse gasses being released into the atmosphere on daily basis. This also pollutes our environments causing us serious environmental problems. Although, energy utilization is of high demand especially in Africa as the population grow geometrically without a corresponding geometric energy generation, storage or distribution. Therefore, other sources of energy have to be harnessed for a comprehensive utility in home and industrial buildings. Some notable energy consumption electronics in our homes include Refrigerators, Air conditioners, water heaters, water desalination, washing machines etc. The demand on the electricity is immensely increasing (D. Abdulwahab 2012, A. Ahmad, & Daut I, 2013). About 60% of energy used in buildings are consumed in air conditioning systems in tropical regions of the world (D. Abdulwahab 2011, A. Ahmad, & Daut I, Ravi Gugulothu, 2015). This led to large electricity demand, which in turn leads to an increase in the peak electric load. This undoubtedly becomes a major cause of power system instability and system failure. This increased energy demands as well as the negative environmental effects of the fossil fuel has led to substantial research, investigation and application of renewable energy sources such as wind, solar, hydro or tidal power for over the past few decades. Again, the combination of various renewable energy sources is becoming more pragmatic in renewable energy applications. In recent years, the application of Photovoltaic (PV) systems has increased dramatically (Deji A., Sheroz K, Musse M.A, Jalel C. (2011), A. Ahmad, & Daut I, Ravi Gugulothu, Abdulwahab D. (2016), Bilgili M., 2011). PV system is considered as a clean and sustainable source of electricity (Abdulwahab D, Abdulwahab, Deji & Cong G 2017). PV systems have become very attractive for air conditioner application because the peak demand for cooling coincides with the period of the high solar radiation (Ravi Gugulothu et al., 2015). Furthermore, the operation cost of a PV system is very low compared with other energy sources and the average lifetime for PV solar equipment varies from 20 to 30 years. Abdulwahab, D., Khan, S., Chebil, J., & Alam, A. Z. (2011, May). Abdulwahab, D., Khan, S., Chebil, J., Ahmed, M. M., Naji, A. W., & Alam, A. Z. (2010, May). Deji A., Sherifah O.M., 2023. Deji A., Sheroz K, Musse M.A, Jalel C. (2011), Deji A., Sheroz K., Musse M.A., (December 2023), Deji A., Sheroz K., Musse M.A., (December 2023), Deji A., Hanifah A.M., Sherifah O.M., (December 2023), Deji A., Sheroz K, Musse M.A, Jalel C. (August 2014), Deji A., Sheroz K, Musse M.A, Jalel C. (2011), D. Abdulwahab, S. Khan, J. Chebil and A. H. M. Z. Alam 2012, Elfaki, H. M. O. A. , Sherifah O. M, Deji A. (2023).

Solar PV technology is one of the alternatives to conventional energy sources with great potential contribution to solving energy issues. Even with the combination of fossil power plants and renewable energy applications, (e.g. PV system), (that is PV systems with fossil power plant), it will still considerably mitigate the adverse effect of fossil fuels on the environment. The need to reduce CO<sub>2</sub> emissions has affected the price of photovoltaic systems, and solar modules in particular, making application of photovoltaic more profitable.

The research area is found to have high level of solar radiation, with the development of solar energy sector including solar thermal, solar photovoltaic and solar water pumps. Using PV solar system to power the air conditioning system is productive proposition since Nigeria is relatively a hot country and air conditioning systems consume huge amount of the electricity. The over dependence on gas for electricity generation may affect the country's economy especially as electricity is subsidized by the government in Nigeria. PV system can be provided as a long-term strategic plan for electric power consumption which will help to cut down the

operation cost of conventional power plants as well as reduce CO<sub>2</sub> emissions. In Nigeria, the government's buildings are the second highest consumer of electricity making up 19% of the total energy consumption. Therefore, air conditioners are recorded as having the largest portion of the monthly electricity consumption with an average operation of 14 hours per day, and an air conditioner takes up about 72% of Nigerian's household's monthly electricity cost (Deji A., Sherifah O.M., 2023, Deji A., Sheroz K., Musse M.A., (December 2023), Deji A., Sheroz K., Musse M.A., (December 2023), Deji A., Hanifah A.M., Sherifah O.M., (December 2023),

Air conditioning system can be operated with different technologies such as electric-vapor compression refrigeration (SE-VCR). Goswami (Bilgili M, 2011), has investigated solar SE-VCR where the study is carried out in Adana city in Turkey. Minimum photovoltaic panel surface area and maximum compressor power consumption are obtained and, it was found that the SE-VCR system could be used for home/office-cooling purposes during the day. Inverter in air conditioners is one of the new technologies that provides more efficient as well as less power consumption. Aroon et al (Abdulwahab Deji, 2011) have presented the application of the inverter air conditioner using the back-to-back converter. The main aim of this technique is to provide the reactive power during the steady-state operation. In this study, a 3-phase has been used for the experimental setup to support the reactive power back to the utility grid system. The results show that remained power rating during steady state can be used to compensate the reactive power as a function of smart home which can be applied with home energy management system.

Compressor in air conditioner can be powered with DC motor drive or AC motor drive. DC compressor requires high DC current which can be provided by PV solar system. In reference (Aroon A, Maneeinn C & Khomfoi S, 2017), solar PV power has proven to be reliable to drive DC motor for air conditioning system. In this design, it is recommended to supply high DC voltage from the PV panels which can be done by connecting them in series with respect of quintiles of PV panels. As a result, there is no risk with using two types of energy modes of mutual interference either in analysis or experimentation. Deji A., Sherifah O.M., (2023), Deji A., Sheroz K, Musse M.A, Jalel C. (2011), Deji A., Sheroz K., Musse M.A., (December 2023), Deji A., Sheroz K., Musse M.A., (December 2023), Deji A., Hanifah A.M., Sherifah O.M., (December 2023)

DC inverter air conditioning system is considered as one of the best technologies for saving power in air conditioning system. Waleed et al (Cong G et al., 2017) have investigated two air conditioning systems in order to cut down the peak load and its risks in summer. DC inverter air conditioning system has been recommended in this study in Bahrain because it is cost effectiveness. Air conditioning equipment using DC power supply system was discussed in reference (Elzanati W. M et al., 2013). Air conditioner load is significantly affected by the temperature along with characteristics of randomness, distribution, diversity, and intermittence.

In air conditioner applications, the conventional single-phase induction motors have been widely used as fan or compressor motors for a long time. However, its efficiency and power density are quite low and the motor speed is not adjustable. According to (Yukita Kazuto et al., 2017), brushless DC (BLDC) motor is considered rather than induction motor in efficiency, structure, and power density. Thus, this is used in air conditioner applications. Experimental results showed as well as that the implementation of system has been successful.

Recently, many solar air-conditioning systems have been developed and tested including

solar-absorption, solar adsorption and solar-vapor compression systems. Solar-absorption and adsorption systems are powered mainly through solar thermal energy system. Two different technologies of solar air-conditioning have been discussed in reference (Pumira P & Konghirun M, 2011). They are solar thermal absorption refrigeration and PV vapor compression. This study concludes that PV vapor compression air-conditioning systems are more convenient due to smaller surface area as well as higher coefficient which were compared with solar thermal absorption refrigeration systems. Deji A., Sherifah O.M., (2023), Deji A., Sheroz K, Musse M.A, Jalel C. (2011), Deji A., Sheroz K., Musse M.A., (December 2023), Deji A., Sheroz K., Musse M.A., (December 2023), Deji A., Hanifah A.M., Sherifah O.M., (December 2023). In recent years, the world has put a significant effort to cut down the electrical energy consumption which is one of the major causes of climate change and global warming. Applications of solar air conditioning assisted systems in Sub-Saharan Africa for residential buildings in reference (Hamdan O.M et al., 2017). Here, the demonstration of the possibility to implement an air conditioning system powered by solar have been presented. Refrigerant with low Ozone was used which could reduce depletion potential and global warming potential risks. In (Pmatenda M, Raji A & Fritz W, 2014), a design of six air conditioners systems is investigated. The proposed system is stand-alone PV system where the batteries are used to compensate the deficit in the electricity generation. The batteries can provide the independence of the system; however, they form around 40% of the total system cost which approximately doubles the cost. Additionally, batteries need to be replaced after few years. In (Bin-Juine Huang et al., 2016), the performance of solar powered air conditioner system in hot and cold weather is investigated. The location of the system is Shanghai, China. The system works steadily in hot and cold weather. A techno-economic analysis for a hybrid solar powered air conditioner system in Ghana is presented in (Y.Li, G et al., 2015). The proposed system has achieved a potential savings compared to the grid electricity.

In this article we present a design of air conditioning grid-connected PV system for a building at Waidsum Open University Office in Oke Agbo Ikorodu Lagos Nigeria. Four alternative methods are considered;

The method used made a correlation of four alternatives of PV to load ratio factor being investigated. In the first instance, the PV system supplied 50% of the energy to the loads. In the second method, the PV system supplied 75% of the energy to the loads. Thirdly, the PV system supplied 100% of the energy to the loads. Fourthly, on a final design, the PV system supplied 125% of the energy to the loads.

## SOLAR ENERGY RESOURCE IN NIGERIA

Nigeria has high potential of solar energy availability. The solar radiation in Nigeria is shown in Figure 1. The solar radiation is in the range between 4.7 to 5.8 kWh/m<sup>2</sup> per day, which is considered as high range level globally. The irradiation is obtained using different sources such as NASA statistical data, estimation using Angstrom method, and measured data. The estimated values are higher than the measured and NASA statistical data, whereas both the measured and the data from NASA are approximately equal. However, all data values are realistic since they are within the reasonable global range of the irradiation. On this article, the

NASA statistical data has been used to design the PV system due to its reliability and its regular updates as well as the flexibility to access the irradiation history.

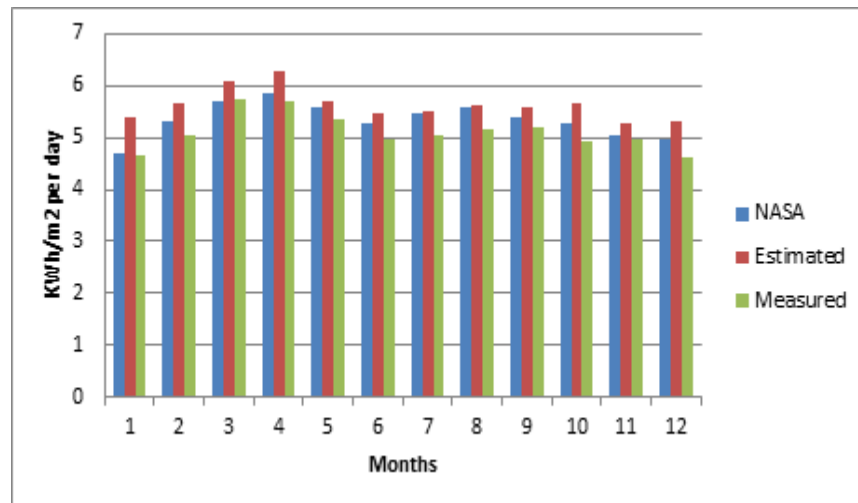

**FIGURE 1**  
**THE SOLAR RADIATION IN LAGOS NIGERIA**

### The Electricity Consumption of The Air Conditioning System

A case reference is made utilizing the WOU's building looking at the air conditioning systems' equipment and components. As a sample, the faculty of Computer and Information Communication Technology at WOU is the proposed research point where the system is implemented to provide the test-bed. The faculty of CICT at WOU uses split air conditioners that cool all rooms inside the building. There are different capacities of the air conditioners used in the building and each one consumes different electricity. However, the time that the air conditioners run per day is equal, which is 8.5 hours per day (08:00 AM- 04:30 PM). On Saturdays and Sundays, the air conditioning system is turned off. This means that these two days are not considered in the estimation of the electricity consumption in this finding. These air conditioners are based on inverter technology. In order to find the electricity consumption per day/week/month, it is required to find in Watt the rating of all devices and the operation duration in hours with respect to the device's parameters. The input rating power of the air conditioner is determined from the data sheet of the air conditioners. The details of the electricity consumption of the air conditioning system in faculty of CICT at WOU is shown in Table 1. The energy consumption of the faculty of CICT at WOU is 305.03 kWh per day as shown in Figure 3.

An inverter air conditioner’s compressor is controlled by integrated controller which can adjust the speed and the frequency of the compressor’s motor according to the temperature required in the room. This technology plays a role in the energy consumption which decreases the duration of the compressor working time. In this article, the ratio of the compressor working time needs to be considered since all the air conditioners used, are an inverter technology which means that the compressor does not run all the time. In order to measure the exact energy consumed, it is required to use special equipment that can measure the electricity consumed in a certain electrical appliance. In this article, POW R2 energy monitor is used to measure the energy consumption of one air conditioner in order to determine the ratio of the compressor working time. POW R2 is connected to the air conditioner for 8.5 hours to investigate its energy consumption and to find the ratio of the compressor working time. The energy monitor POW R2 is connected to mobile application via Wi-Fi, the POW R2 is shown in Figure 4

The effective technique to enhance the performance of a PV air conditioning system is direct expansion in air conditioner when combining with a vacuum solar collector that is installed after the compressor as shown in Figure 2.

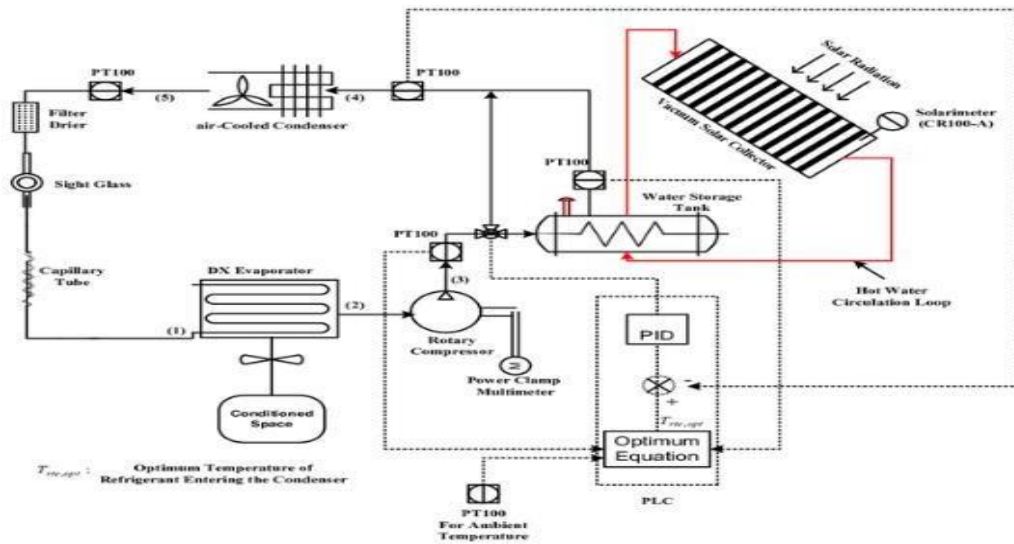

**FIGURE 2**  
**COUPLED PV AND AIR CONDITIONING SYSTEM COMPONENTS**

Consumption per month (kWh)	Consumption per week (kWh)	Consumption per day (kWh)	Quantity	No. of Hours	Rating/Watt age (Watt)	Item
4207.5	1051.875	210.375	15	8.5	2750	Carrier inverter R410A 2.0HP
1795.2	448.8	89.76	4	8.5	4400	Carrier inverter R410A 2.5HP
97.92	24.48	4.896	1	8.5	960	Carrier inverter R410A 1HP
6100.62	1525.155	305.031	20	25.5	8110	Total

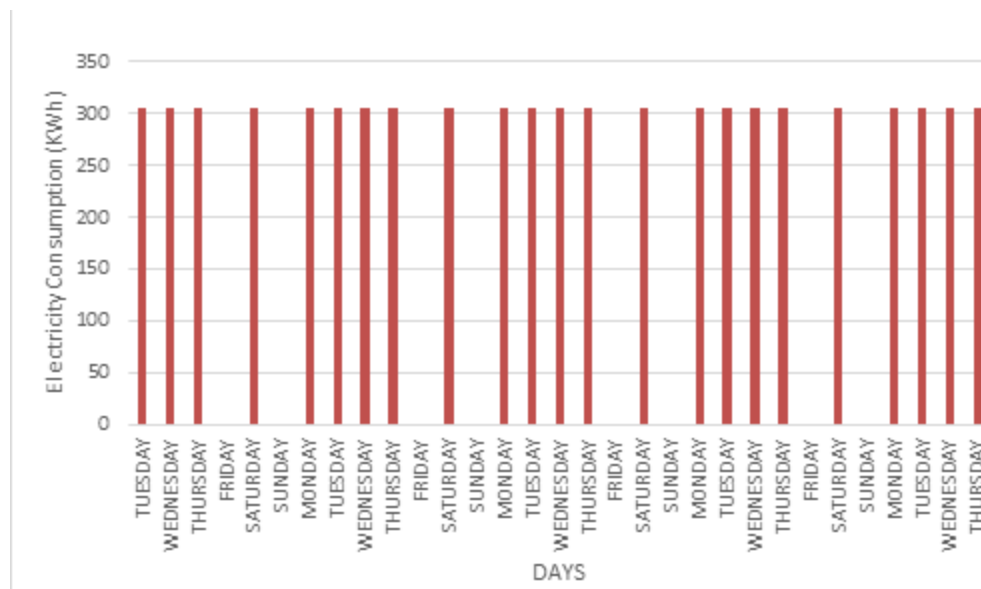
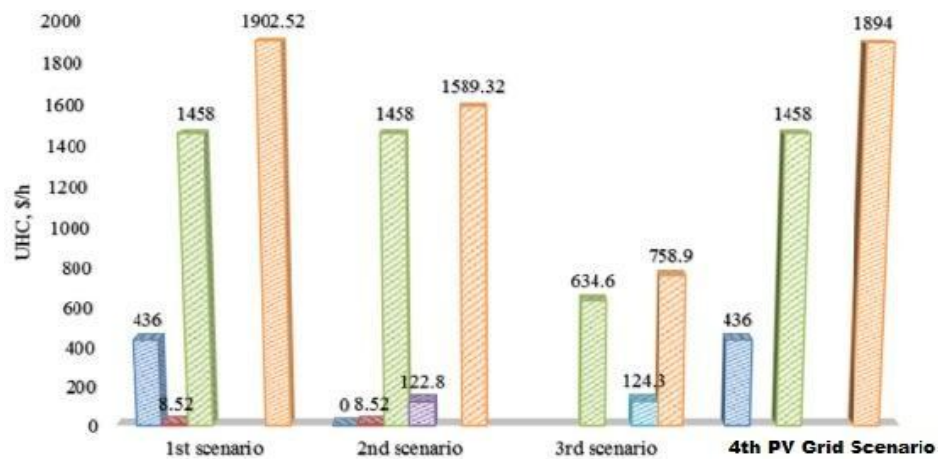

**FIGURE 3  
THE ENERGY CONSUMPTION FOR JANUARY 2023**



**FIGURE 4**  
**The POW R2**

5. An hourly cost for all scenarios, for the 50%, 75%, 100% and 125% are shown in figure



**FIGURE 5**  
**THE HOURLY COST FOR SCENARIO PER UNIT**



## The Design of The PV System

Setting up and putting to size of the PV system is the main part of the system design. In this section, different parameters of solar PV system will be calculated and optimized. This includes; electricity generated, the electricity consumed, and the electricity feed into the grid. The feed-in tariff is the price that the electrical company will pay to the customers who have PV systems installed at their houses. In the recent years the feed-in tariff policies have contributed to the expansion of the PV technology. The maximum output power is totally based on the peak-sun hour. The amount of solar radiation, or insolation, delivered by the sun varies throughout the day, based on the sun's position in the sky, clouds, and other atmospheric conditions. The peak-sun hour was already obtained from the previous section in the solar irradiation data. The maximum output power equation is described by:

$$P_{max} = \frac{E_{per\ day}}{peak-sun\ hour(h)} C_{sys} \eta_{sys} \quad (1)$$

Where:  $P_{max}$  is the maximum output power generated by PV system in kW.  $E_{per-day}$  is the electricity consumption per day.  $C_{sys}$  is the capacity of the system and  $\eta_{sys}$  is the efficiency of the system. In this article, the capacity of the system is changing from 50% to 125%. The total efficiency  $\eta_{sys}$  was estimated as 85% where all the losses have been considered. The losses that are included are the inverter losses (2%), The temperature losses (6%), DC cables losses (2%), AC cables losses (2%), and shading weak irradiation (3%). The total losses are estimated to be 15 % so the efficiency of the system equals to 85% as it shown in Figure 6.

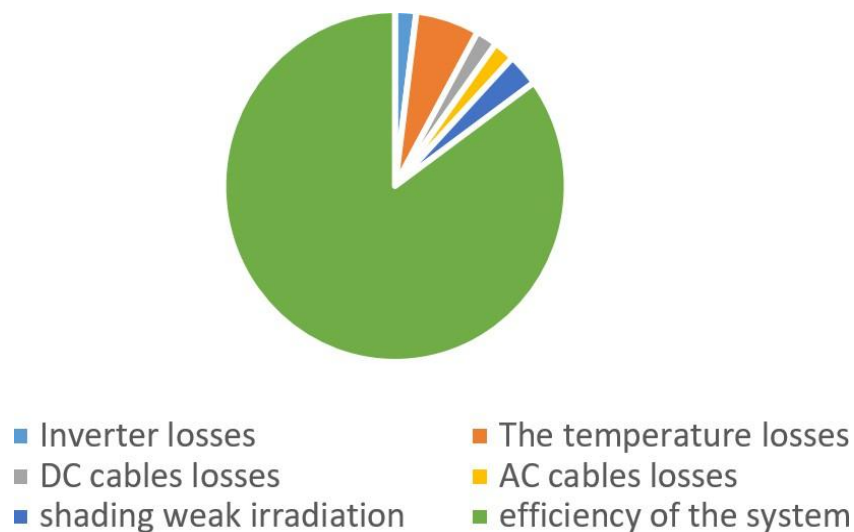

**FIGURE 6**  
**THE TOTAL LOSSES IN THE SYSTEM**

SketchUp Skelion is a tool that can be used to design solar thermal or solar PV systems starting from a 3D model. It can simulate the sunny area in a certain location for studying the shading effects. It has a feature to export the report of the capability of the system by using PVsys and Google Earth. The shading is also be simulated in order to obtain the suitable area for installing the PV modules in order to reduce the shading losses. In this article, the area of the project on the top of the roof of faculty of CICT at WOU has been simulated by SketchUp Skelion for studying the available area that is not affected by the shadow. In addition, the sun path chart was created based on the latitude and longitude of the project's location. The location of this project was determined by the Google earth tool so as to ensure that the sun position is accurate. The shading of the nearby buildings is also considered as well. The simulation has indicated the area that are not affected by the nearby buildings shading. Therefore, the shading between the PV panels that is created by the tilt angle is avoided by calculating the minimum distance between each PV panel. The simulation model for the area and shadow calculation is shown. From the figure 7, the available area is 760 m<sup>2</sup>.

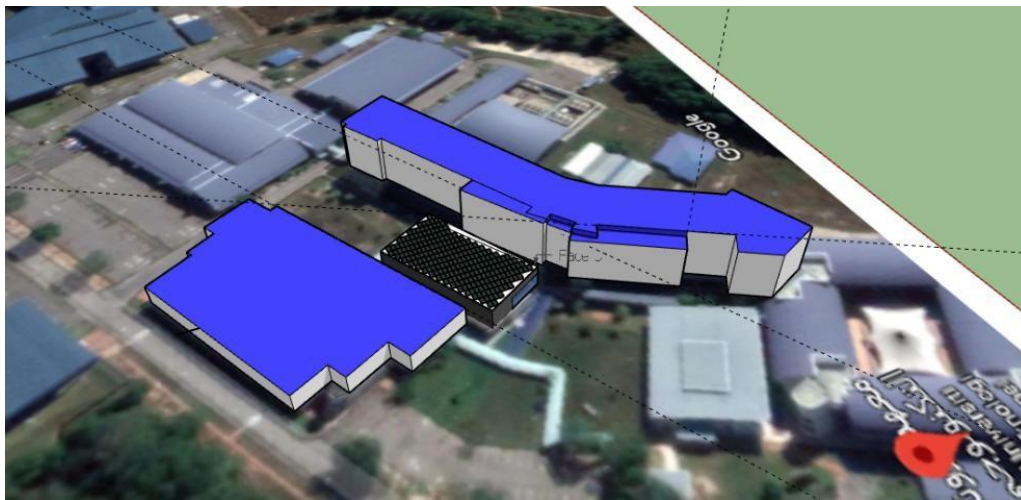

**FIGURE 7**  
**THE TOP VIEW OF SIMULATED PROJECT LOCATION WITH NEARBY BUILDINGS**

The figure 8 shows the complete schematic diagram of a grid-connected PV system with battery storage. A battery (200 V) is connected to the intermediate DC bus through a class C dc-dc converter. The inductance of L2 is equal to 2 mH and it presents a parasitic resistance of 0.5  $\Omega$ . Assume that the system is to operate in the stand-alone (islanded) mode, with the load being

supplied with 220 VLL and 60 Hz. The local load is assumed to be resistive rated at 5 kW. The DCAC converter operates with SPWM and a carrier signal of 15 kHz.

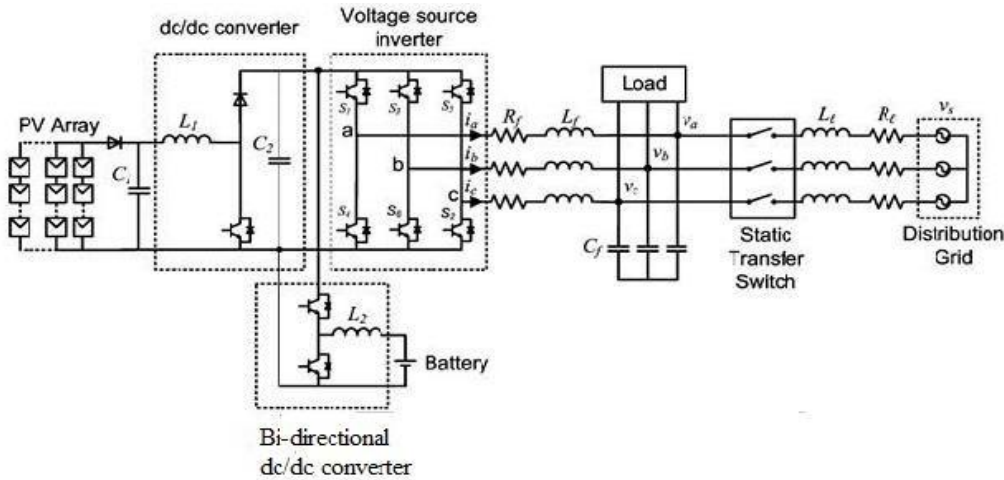

**FIGURE 8**  
**THE PV SYSTEM TO GRID NETWORK**

### The Economic Analysis

An economical evaluation is made to utilize the cost-benefit of different configured PV systems. Some of the economic terms considered are; payback time, net present value (NPV), internal rate of return (IRR), feed in tariff, and cash flow return rate. Besides, the cost of the PV system components. The NPV method is used to calculate the present value of the future cash flows and is a common way of evaluating PV systems. This project is considered profitable when the  $NPV > 0$ . The payback time shows how long it will take to get the investment back, while NPV shows the profit one can expect at the end of the investment period. The NPV present is calculated by:

$$NPV = \sum_{t=0}^T \frac{C_t}{(1+r)^t} = \sum_{t=0}^T \frac{Revenue_t - Costs_t}{(1+r)^t} \quad (2)$$

Where  $t$  is the year of operation,  $C_t$  is the net cash flow,  $T$  is the lifetime of the system,  $r$  is the discount rate, Revenue is the cash inflow and Costs is the cash outflow. IRR is the interest rate at which the net present value of all the cash flows (both positive and negative) from this project or investment equal zero. Internal rate of return is used to evaluate the attractiveness of a project or investment. If the IRR of a new project exceeds a company's required rate of return, that project is desirable. When the IRR falls below the required rate of return, the project should

be rejected. In order to calculate IRR using the formula of NPV, one would set NPV equal to zero and solve for the discount rate ( $r$ ), which is the IRR. Because of the nature of the formula, however, IRR cannot be calculated analytically and must instead be calculated either through trial-and-error or using software programmed to calculate IRR.

When using feed-in-tariffs (FiTs), electricity generated by the PV system can be sold to the grid utility for a fixed price. A smart meter or two analogue electricity meters are required for this system. In a net feed-in-tariff only the surplus electricity is sold to the grid. In Nigeria, selling the electricity to the grid by PV system grid-connected is still under consideration although the feed in tariff was estimated to be equal to 30 naira per KWh [19]. This estimation is done based on the levelized cost of the conventional electricity generation. This study therefore recommends starting with the feed-in tariff scheme as the key policy framework to stimulate private investments and to scale-up deployment of renewable energy technologies. In the future, once PV tariff reforms are introduced and coupled with declining technology costs, and once solar PV power generation achieves or approach close to grid parity, net metering could be introduced (Romeo Pacudan, 2018; Ha, Quang & Vakiloroyaya, Vahid, 2012; Elfaki Ahamed, O.M.H, Sherifah O.M., Deji A., 2023).

## RESULTS AND DISCUSSIONS

Here, four alternatives method are considered; 1) the PV system supplies 50% of the loads, 2) the PV system supplies 75% of the loads, 3) the PV system supplies 100% of the loads, and finally 4) the PV system supplies 125% of the loads. The parameters of the system used in this article are given in Table 2. The overall output results of the system are the output parameters that are required for the installation such as the number of the modules and required area. Additionally, the economical parameters included in this research work are; the payback time, the capital cost and IRR. The output results are shown in Table 3. The change in the inputs will be accrued in the cost of the inverter, cost of the installing of the system, operation and management cost and the rest inputs which remain constant. The PV production, electricity consumption and the electricity feed-in for the three alternatives methods are shown in Figures 9-11. The cash flow for the three alternatives are shown in Figures 12-14.

As it is clearly shown in Figure 9, the electricity exported into the grid is negative because in this case the system depends on the grid where the grid is supplying the building with 50% of the required electricity. In this case, no monthly income from the system but the users need to pay half of the electricity with no PV system implemented. In the case of 100% capacity the net cash flow has increased and there is amount of incoming profit from the system. However, the discounted cash flow is less than cash flow without discount rate which is assumed to be 5%. The profit of this system in this case is estimated to be equal to USD\$87,880 over the lifetime of the project.

The output power of the system with 125% capacity equals to 69 KWp. The payback time has decreased to 7.8 years which shows this alternative is profitable. The net cash flow in this case has increased. However, the discounted cash flow is less than cash flow without discounted rate which is assumed to be 5%. The profit of this system in this case is estimated to be USD\$ 245,819 over the lifetime of the project. Whereas the profit with the discounted rate can reach USD\$ 95,497.

<b>System Parameter</b>	<b>Value</b>	<b>System Parameter</b>	<b>Value</b>
<b>The daily power consumption</b>	305.031 kWh	Cost of the inverter	30,000 \$
<b>The efficiency of the system</b>	85%	System Capacity	50% - 125%
<b>Available Area</b>	760 m <sup>2</sup>	Feed in tariff	0.3 \$
<b>Max output power of the PV panel</b>	300 W	Discount rate	5%
<b>Area of each panel</b>	1.9 m <sup>2</sup>	Depreciation	0.05%
<b>The cost of PV panel</b>	180 \$	Electricity tariff	0.1 \$
<b>Cost of the system</b>	30,000 \$	O&M cost per year	O&M cost per year

<b>System Parameter</b>	<b>Value</b>	<b>System Parameter</b>	<b>Value</b>
<b>The system output capacity</b>	66.245 kWp	The system total income	12983.34 \$
<b>No of PV modules</b>	221	The payment back time	8.6 years
<b>The area needed for the system</b>	420 m <sup>2</sup>	The cash flow return rate	11.70%
<b>Total cost of the system</b>	112247.12 S	The net present value	\$106,924.69
<b>The life time</b>	25 years	The internal rate of return	6.36%

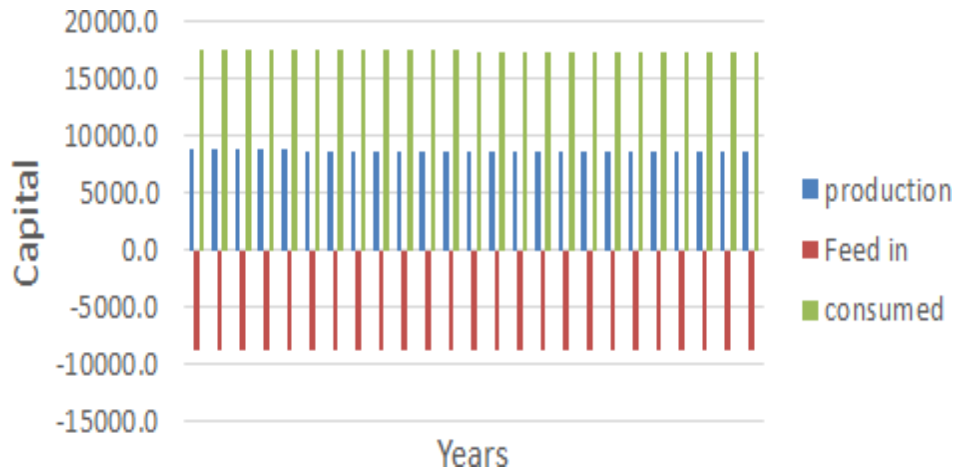

**FIGURE 9**  
**THE PV PRODUCTION, THE ELECTRICITY CONSUMPTION AND THE ELECTRICITY FEED-IN WITH 50% CAPACITY**

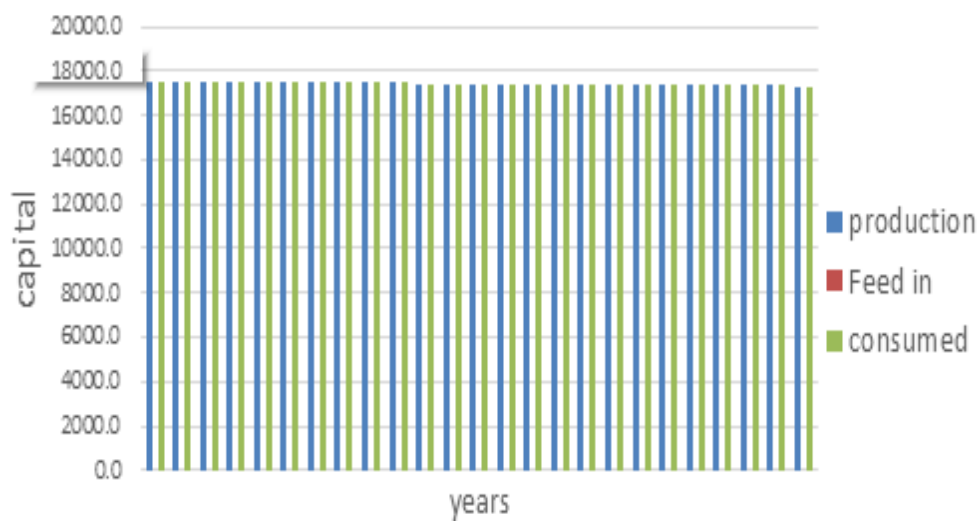

**FIGURE 10**  
**THE PV PRODUCTION, THE ELECTRICITY CONSUMPTION AND THE ELECTRICITY FEED-IN WITH 100% CAPACITY**

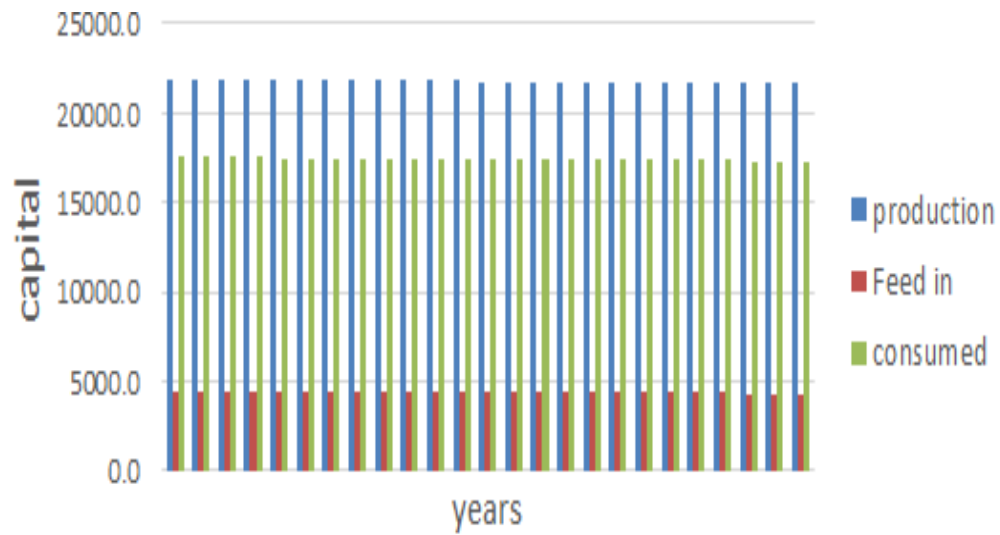

**FIGURE 11**  
**THE PV PRODUCTION, THE ELECTRICITY CONSUMPTION AND THE ELECTRICITY FEED-IN**  
**WITH 125% CAPACITY**

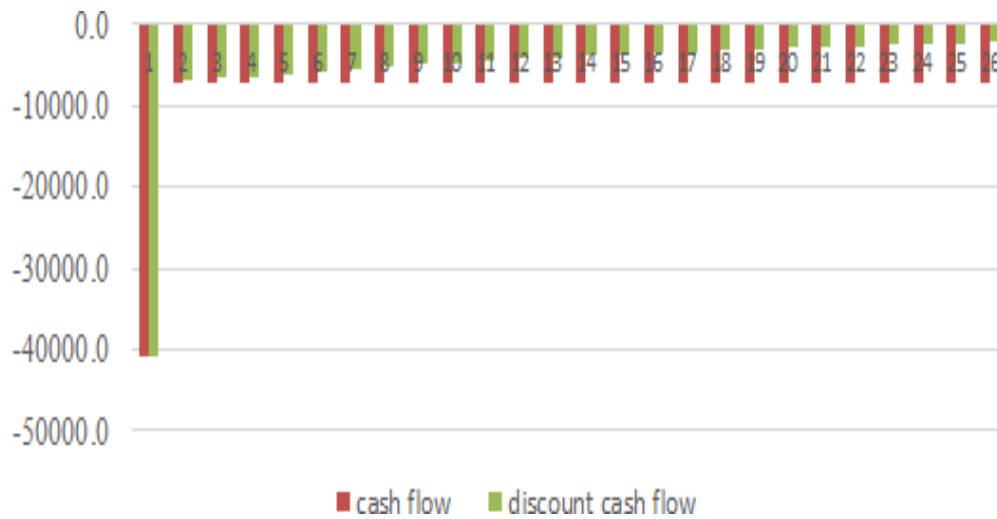

**FIGURE 12**  
**THE CASH FLOW WITH 50% CAPACITY**

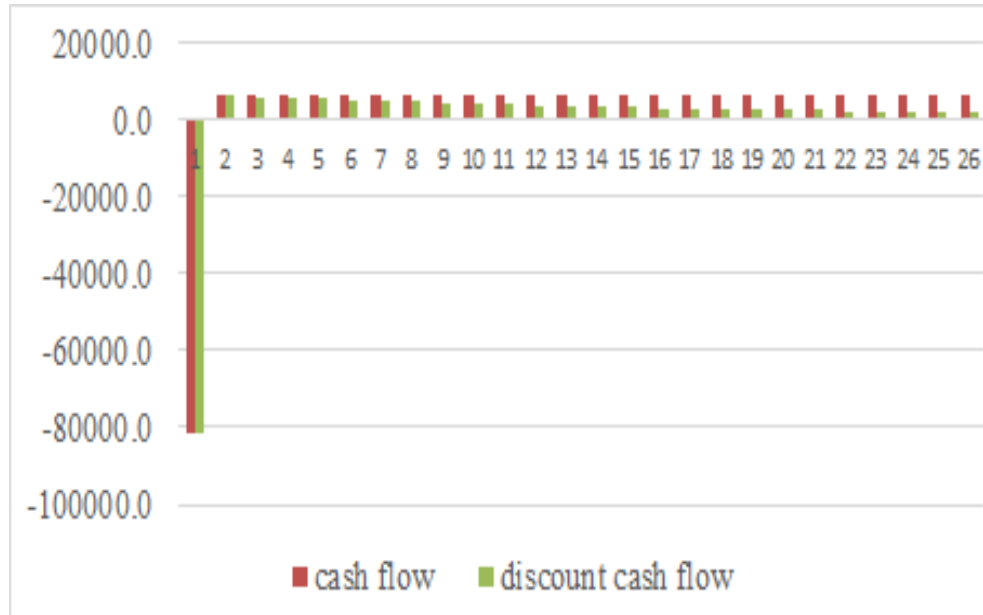

**FIGURE 13**  
**THE CASH FLOW WITH 100% CAPACITY**

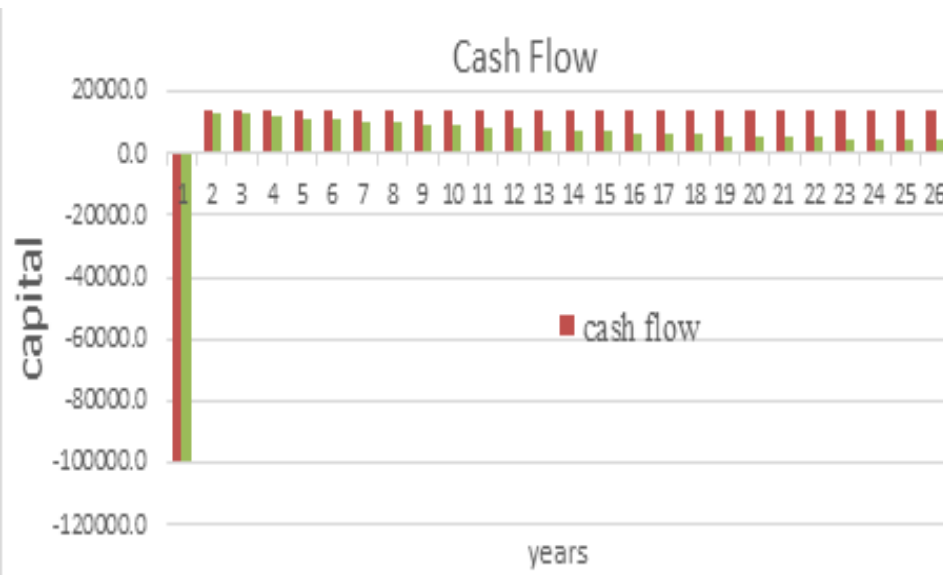

**FIGURE 14**  
**THE CASH FLOW WITH 125% CAPACITY**



## CONCLUSION

Four alternatives have been investigated for a PV powered air conditioning system in Ikorodu Lagos Nigeria. The capacity of the system ranges from 50% to 125%. The main purpose of this study is to find weather the solar powered PV system is techno-economic feasible or not. It's discovered that the most cost-effective option is the PV system with capacity rate of 125%, which has the highest profit over the lifetime of the project and the shortest payback time with 7.8 years. In addition, the 50-100% capacity rates can be considered as suitable solution for limited budget. The feed in tariff in Nigeria is assumed to be 0.3 cents as proposed in some previous research. In this study the feed-in tariff, the interest rate and the inflation rate are assumed to be constant.

## REFERENCES

- Abdulwahab, D. (2011). Development of Differential Sensor Interface for GSM Communication (Masters dissertation, Kulliyah of Engineering, International Islamic University Malaysia).
- Abdulwahab, D. (2016). Development of Differential Inductive Transducer System for Accurate Position Measurement (Doctoral dissertation, Kulliyah of Engineering, International Islamic University Malaysia).
- Abdulwahab, D., Khan, S., Chebil, J., & Alam, A. Z. (2011, May). Symmetrical analysis and evaluation of Differential Resistive Sensor output with GSM/GPRS network. *In 2011 4th International Conference on Mechatronics (ICOM) (pp. 1-6). IEEE.*
- Abdulwahab, D., Khan, S., Chebil, J., Ahmed, M. M., Najji, A. W., & Alam, A. Z. (2010, May). Identification of linearized regions of non-linear transducers responses. *In International Conference on Computer and Communication Engineering (ICCCE'10) (pp. 1-4). IEEE.*
- Ahmad, A. (2014). Electricity consumption in Brunei Darussalam: Challenges in energy conservation. *International Energy Journal*, 14(4).
- Aroon, A., Maneeinn, C., & Khomfoi, S. (2017, June). Reactive power compensation using inverter air-condition for smart home application. *In 2017 14th International Conference on Electrical Engineering/Electronics, Computer, Telecommunications and Information Technology (ECTI-CON) (pp. 290-293). IEEE..*
- Bilgili, M. (2011). Hourly simulation and performance of solar electric-vapor compression refrigeration system. *Solar Energy*, 85(11), 2720-2731.
- Cong, G., Wang, R., Wang, X., Yang, X., & Feng, L. (2017, October). Design and experimental study of pv air conditioning drive system. *In 2017 Chinese Automation Congress (CAC) (pp. 7812-7915). IEEE.*
- Daut, I., Adzrie, M., Irwanto, M., Ibrahim, P., & Fitra, M. (2013). Solar powered air conditioning system. *Energy Procedia*, 36, 444-453.
- D. Abdulwahab et al., "Identification of linearized regions of non-linear transducers responses," International Conference on Computer and Communication Engineering (ICCCE'10), Kuala Lumpur, 2010, pp. 1-4, doi: 10.1109/ICCCE.2010.5556753.
- Deji A., Sherifah OM., 2023. The Mediating Effect of Entrepreneur Cash Waqf Intension as means of Planned Behaviour for Business Growth. *International Journal for Multidisciplinary Research*. Volume 5, Issues 6, page 1-22
- Deji A., Sheroz K, Musse M.A, Jalel C. (2011). Design of Differential Resistive Measuring System and its applications. A book chapter in IJUMPRESS on Principle of Transducer Devices and Components. 17 1528-2686-30-S1-002

**Citation Information:** Deji, A., Khan, S., Habaebi, H.M., Musa. O.S. (2024). Technical Engineering Evaluations And Economic Feasibility Study Of Solar Powered Air Conditioning System In Tier Three Nations. *Academy of Entrepreneurship Journal*, 30(S1), 1-19.

Chapter 17, page 107.

- Deji A., Sheroz K., Musse M.A., (December 2023) “Analytical Modeling of Electrical Frequency and Voltage Signal from a Differential Inductive Transduction for Energy Measurement. *International Journal for Multidisciplinary Research*. Volume 5 Issue 6 Page 1-19. Deji A., Sheroz K., Musse M.A., (December 2023) “Kinematic Motion Modelling from Differential Inductive Oscillation Sensing for a Seismomechanism and Electromechanical Devices and Applications. *International Journal for Multidisciplinary Research*. Volume 5 Issue 6 Page 1-15.
- Deji A., Hanifah A.M., Sherifah O.M., (December 2023) “The Adoption of Information System Technology in Piloting the Current State of Health Institution in Tier Three Nations.” *International Journal for Multidisciplinary Research*. Volume 5 Issue 6 Page 1-13.
- Deji A., Sheroz K, Musse M.A, Jalel C. (August 2014). Analysis and evaluation of differential inductive transducers for transforming physical parameters into usable output frequency signal August 2014 *International Journal of the Physical Sciences* 9(15):339-349.
- Deji A., Sheroz K, Musse M.A, Jalel C. (2011). Design of Differential Resistive Measuring System and its applications. A book chapter in IIUMPRESS on Principle of Transducer Devices and Components. Chapter 17, page 107.
- D. Abdulwahab, S. Khan, J. Chebil and A. H. M. Z. Alam, "Symmetrical analysis and evaluation of Differential Resistive Sensor output with GSM/GPRS network," 2011 4th International Conference on Mechatronics (ICOM), Kuala Lumpur, Malaysia, 2011, pp. 1-6, doi: 10.1109/ICOM.2011.5937149.
- Elfaki, H. M. O. A., Sherifah O.M., Deji A., (2023). Factors Related to Financial Stress Among Muslim Students in Malaysia: A Case Study of Sudanese Students. *Academy of Entrepreneurship Journal*, 29(6). Page 1-15
- Elzanati, W. M., & Ameen, S. Y. (2013, November). Cost effective air-conditioning for bahrain domestic applications. In 2013 7th IEEE GCC Conference and Exhibition (GCC) (pp. 535-540). IEEE.
- Gugulothu, R., Somanchi, N. S., Banoth, H. B., & Banothu, K. (2015). A review on solar powered air conditioning system. *Procedia Earth and planetary science*, 11, 361-367.
- Ha, Q. P., & Vakiloroyaya, V. (2012). A novel solar-assisted air-conditioner system for energy savings with performance enhancement. *Procedia Engineering*, 49, 116-123.
- Hamdan, M. O., & Abu-Nabah, B. A. (2017, April). Solar air-conditioning: Case study of solar absorption versus photovoltaic vapor compression systems. In 2017 7th International Conference on Modeling, Simulation, and Applied Optimization (ICMSAO) (pp. 1-4). IEEE..
- Huang, B. J., Hou, T. F., Hsu, P. C., Lin, T. H., Chen, Y. T., Chen, C. W., ... & Lee, K. Y. (2016). Design of direct solar PV driven air conditioner. *Renewable Energy*, 88, 95-101.
- Khan S., A. Deji, A.H.M Zahirul, J. Chebil, M.M Shobani, A.M Noreha. (September 2012) “Design of a Differential Sensor Circuit for Biomedical Implant Applications”. *Australia. Journal of Basic and Applied. Sciences.*, 6(9): 1-9. 10.1002/9781118329481.ch1.
- Li, Y., Zhang, G., Lv, G. Z., Zhang, A. N., & Wang, R. Z. (2015). Performance study of a solar photovoltaic air conditioner in the hot summer and cold winter zone. *Solar Energy*, 117, 167-179. Matenda, M. P., Raji, A., & Fritz, W. (2014, April). Applications of solar air conditioning assisted systems in Sub-Saharan Africa for residential buildings. In Twenty-Second Domestic Use of Energy (pp. 1-6). IEEE.
- Opoku, R., Mensah-Darkwa, K., & Muntaka, A. S. (2018). Techno-economic analysis of a hybrid solar PV-grid powered air-conditioner for daytime office use in hot humid climates—a case study in Kumasi city, Ghana. *Solar Energy*, 165, 65-74.
- Pumira, P., & Konghirun, M. (2011, August). Digital control of sensorless brushless DC motor drive system with power factor correction for air conditioners. In 2011 International Conference on Electrical Machines and Systems (pp. 1-6). IEEE.
- Romeo Pacudan, “Renewable Energy Working Paper Series Residential Solar PV Policy Feed-in Tariff vs Net Metering Options for Brunei,” *Renewable Energy*, Vol. 122, No.2018, pp.362-374, 2018.

Yukita, K., Hosoe, T., Horie, S., Matsumura, T., Hamanaka, M., Hirose, K., & Noritake, M. (2017, October). Air conditioning equipment using dc power supply system. *In 2017 IEEE International Telecommunications Energy Conference (INTELEC)* (pp. 229-232). *IEEE*.

**Received:** 30-Sept-2023, Manuscript No. AEJ-23-14129; **Editor assigned:** 03-Oct-2023, PreQC No. AEJ-23-14129(PQ); **Reviewed:** 18-Oct-2023, QC No. AEJ-23-14129; **Revised:** 24-Oct-2023, Manuscript No. AEJ-23-14129(R); **Published:** 31-Oct-2023